

USED ON

REF. DRGS.
3301997

PATT.
C/SM
P&C
S.G.
P.L.G.
FIT.
M/C
INSP.
ROUGHNESS NUMBERS

FINISH SYMBOLS

126 . MICRO INCHES OR 3.2 . MICROMETRES
 R / . ROUGH
 N / . NORMAL
 F / . FINE
 FOR JOINT FACES AND JOINT FINISHES TO TOLERANCES TO TOL. FINISHES TO TOL. FINISHES TO TOL. FINISHES TO TOL. FINISHES TO TOL. FINISHES TO TOL. FINISHES TO TOL.

CAD DRAWING NOT TO BE MODIFIED

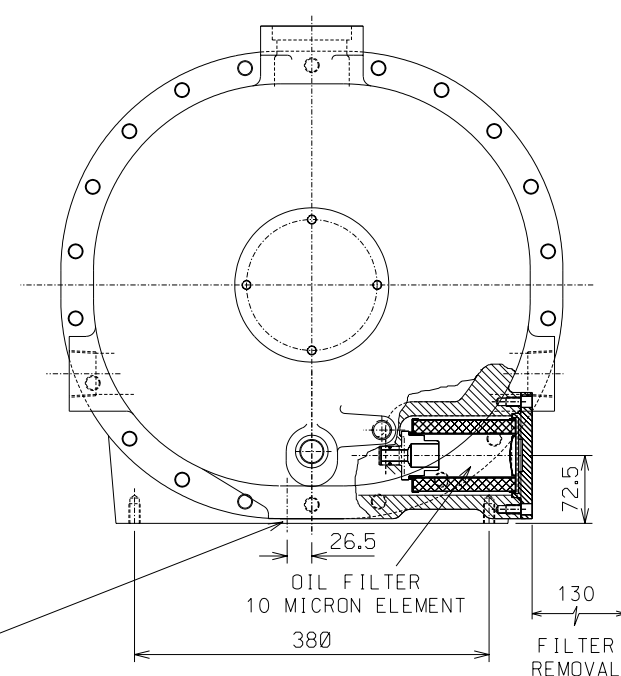
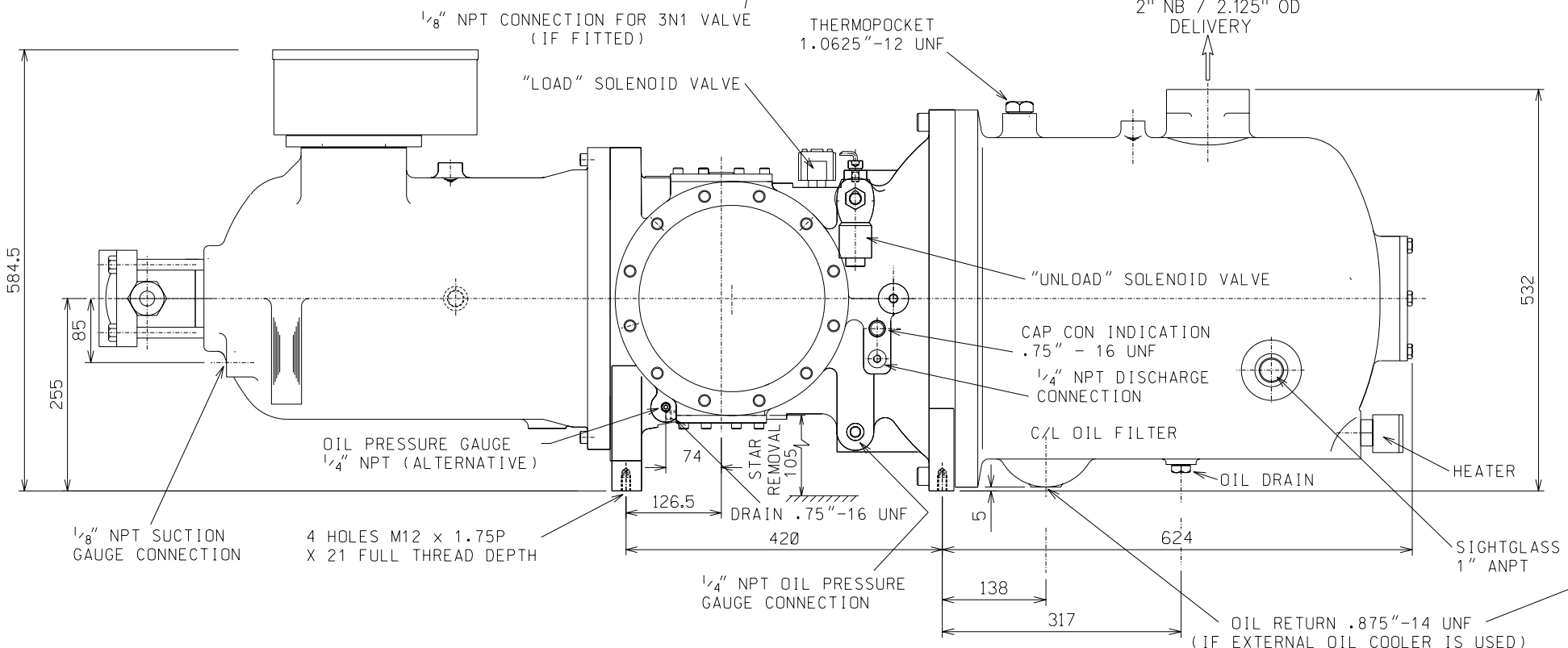
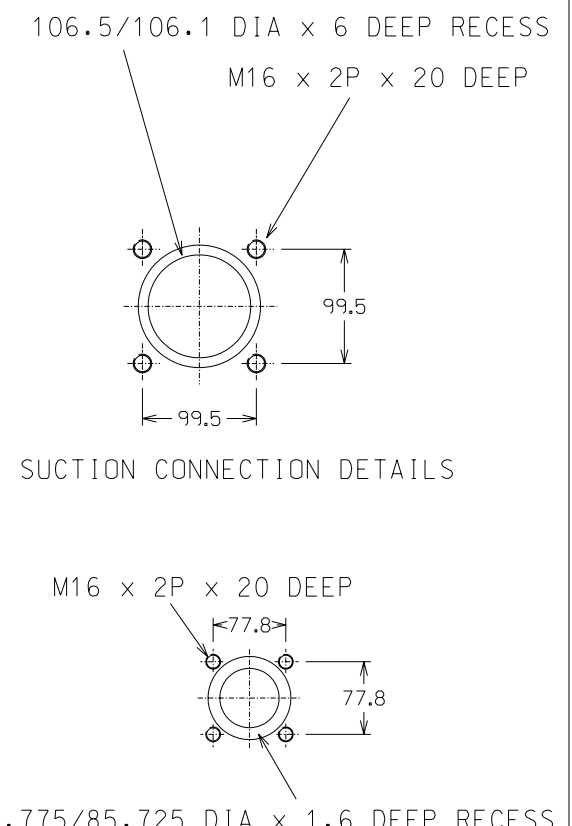
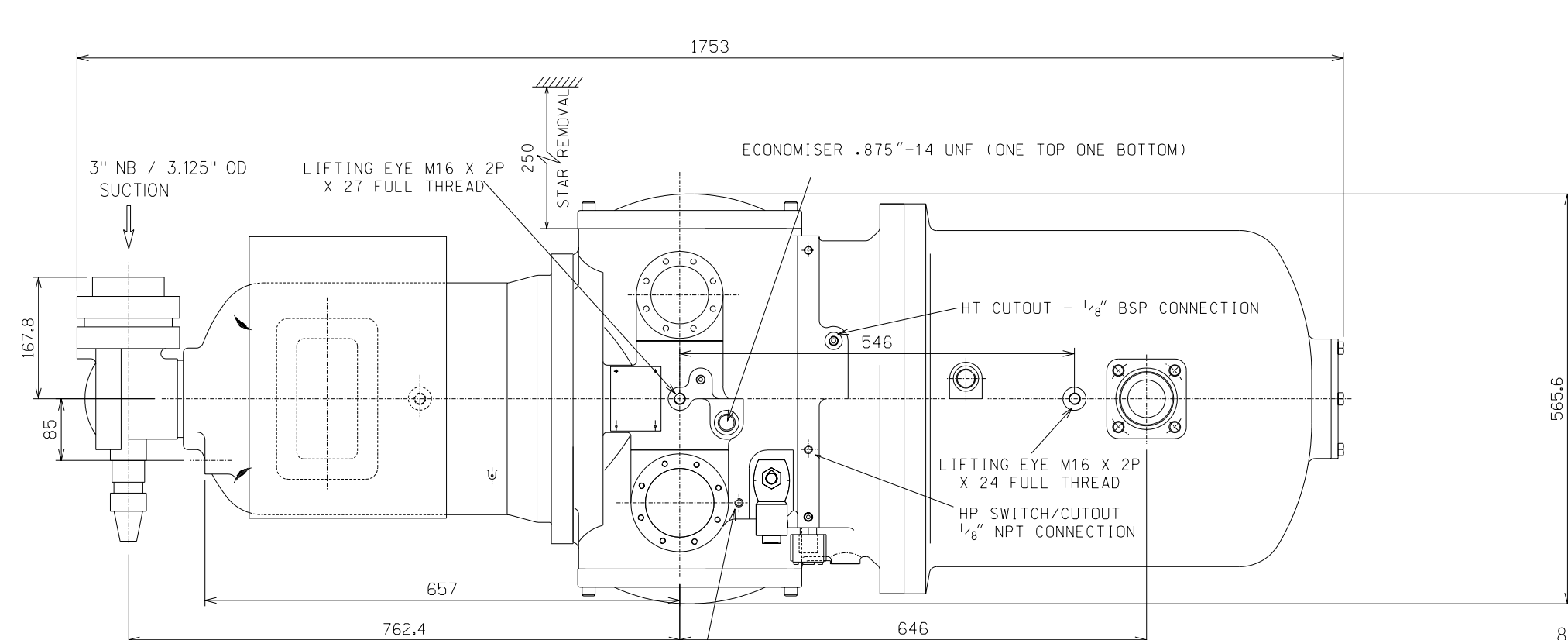

INSPECTION BY
DRAWN
7/11/03
AAE
DATE APPROVED
SIZE A1

5			9			PROTECTIVE FINISH
4			8			PATT NO.
3	DRAWING UPDATED	5/1/05 AAE	7			WEIGHT kg
2	DRAWING UPDATED	14-12-04 AAE	6			SCALE NTS
ISSUE NO	DESCRIPTION OF MOD.	DATE & INITIALS	ISSUE NO	DESCRIPTION OF MOD.	DATE & INITIALS	DIMENSIONS IN MM

TEST PRESSURE psig HYD psig AIR	TOLERANCES EXCEPT WHERE OTHERWISE STATED, (BRACKETED) DIMMS. FOR REF. ONLY. IMPERIAL UNITS FRACT. DIMMS. : .020" DECIMAL DIMMS. : .010"	MATERIAL
TITLE	PHYSICAL DATA HS3200; COMPRESSOR WITH INTERNAL OIL FILTER	

MANU. ORDER NO.	CONTRACT ORDER NO.	REMARKS
<p>THIS DRAWING MUST NOT WITHOUT THE CONSENT OF J & E HALL LIMITED BE SHOWN TO ANY PERSON NOT EMPLOYED BY THE RECIPIENT OR BE COPIED OR USED FOR THE PURPOSE OF MANUFACTURING ANY ARTICLE SHOWN IN THIS DRAWING. THIS DRAWING TOGETHER WITH ANY COPIES MADE BY THE RECIPIENT SHALL BE RETURNED TO J & E HALL LIMITED ON DEMAND. THE COPYRIGHT IN THIS DRAWING SHALL BE AND REMAIN THE SOLE PROPERTY OF J & E HALL LIMITED.</p>		
<p>J&E Hall LIMITED UNIT 48/41, PEARSON WAY, QUESBORO, DARTFORD, KENT, DA1 1JN, ENGLAND</p>		<p>DRAWING CODE NO. D100364</p>
ISSUE NO. 03	SHEET NO. 1 OF 1	